



## **ELECTRON**

Electric Scooter User Manual



SHOKSCOOTERS.COM



## **THANK YOU FOR YOUR PURCHASE!**

This user manual will help you assemble and operate your SHOK Electron electric scooter. Be sure to read all of the information in this manual before riding.

# CONTENTS

1. Package Contents .....	05
2. Scooter Overview .....	06
3. Assembly & Setup .....	07
4. Charging the Scooter .....	08
5. How to Ride .....	09
6. Safety Instructions .....	11
7. Folding & Carrying .....	16
8. Daily Care & Maintenance .....	17
9. Specifications .....	19
10. Parts & Accessories .....	20
11. Error Codes .....	21
12. Warranty .....	22

# PACKAGE CONTENTS

## Assembled Electric Scooter

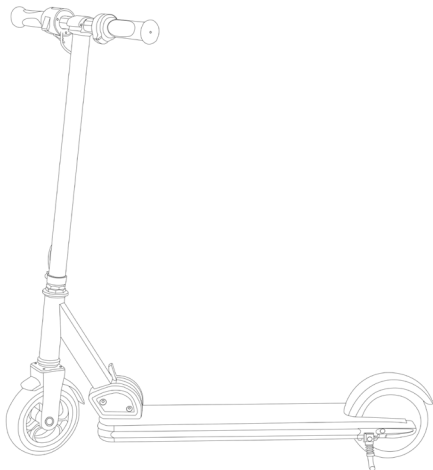

## Materials

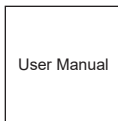

## Accessories

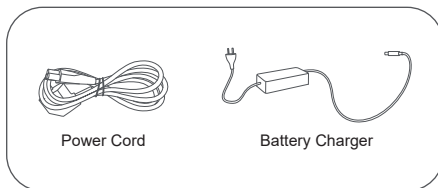

When unpacking your SHOK Electron electric scooter, please verify that the above items are included in the package. If you are missing any components, please contact your dealer/distributor. After verifying that all components are present and in good condition, you can assemble your new SHOK Electron electric scooter.

Please retain the box and packaging materials in case you need to ship your SHOK Electron electric scooter in the future.

Remember to power off the electric scooter and unplug the power cord before assembling.

# SCOOTER OVERVIEW

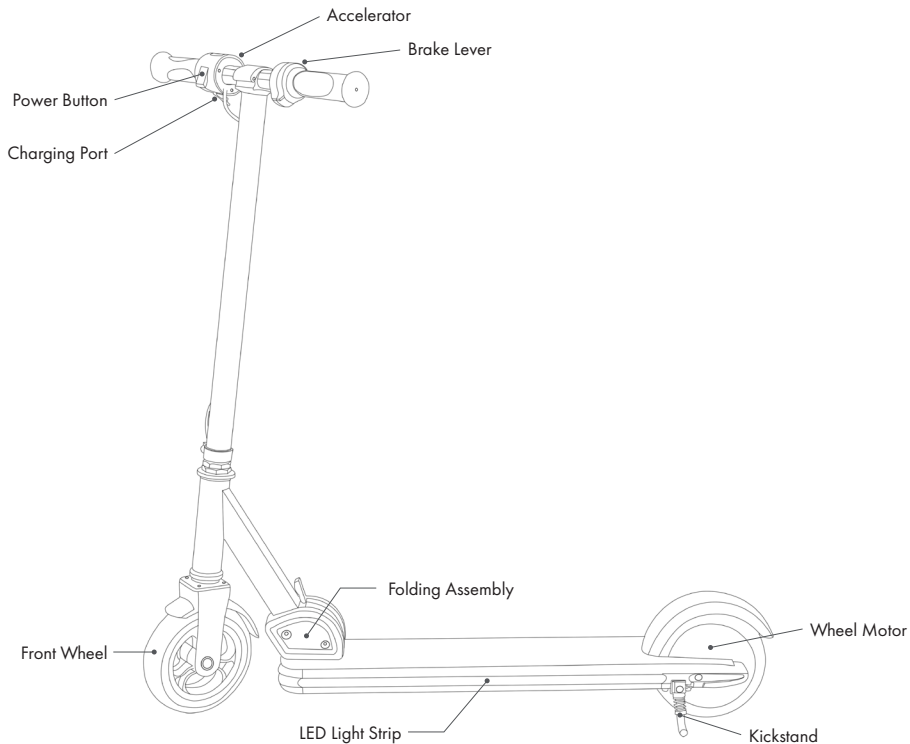

## ASSEMBLY & SETUP

- 1 Place the handlebar on the attachment bracket on the stem.
- 2 Connect the plug on the handlebar to the plug on the stem.
- 3 Tighten the screw with a hex key or wrench.
- 4 Press the power button to turn the scooter on. Press the button again to turn the scooter off.
- 5 Once the scooter is powered on, check the display to ensure that the scooter is functioning correctly.
- 6 Press the light button to turn the headlight on or off.

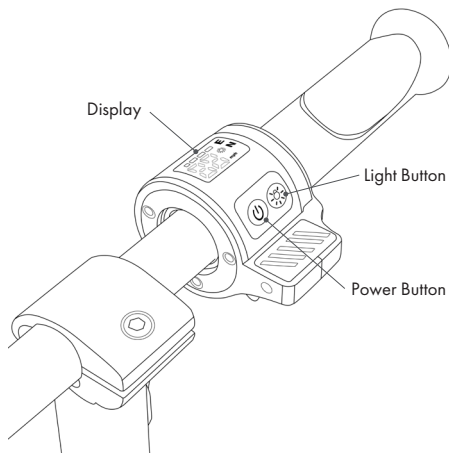
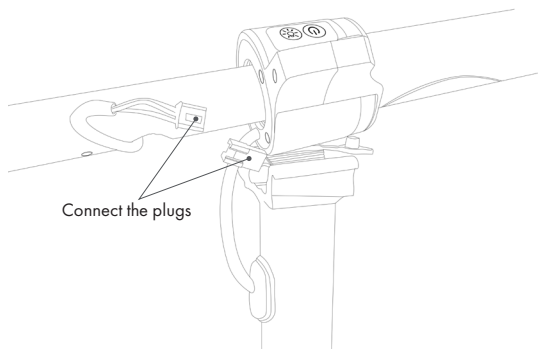

## CHARGING THE SCOOTER

- 1 Open the charging port cover.
- 2 Plug the power adapter into the charging port.
- 3 When charging is completed, unplug the charger and close the charging port cover.

The scooter is fully charged when the LED on the charger changes from red (charging) to green.

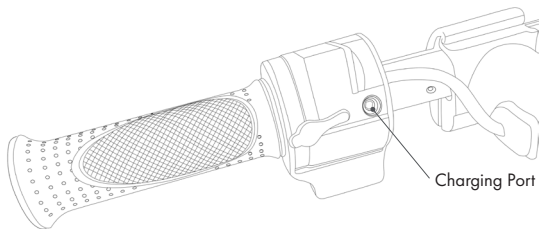

## Safety Warnings

- The charger supplied with the electric scooter should be regularly examined for damage to the cord, plug, enclosure and other parts. In the event of damage, the scooter must not be charged until the charger has been repaired or replaced.
- Use only with the recommended charger.
- Use caution when charging.
- DO NOT operate the charger near flammable materials.
- Unplug the charger and disconnect it from the scooter when not in use.
- DO NOT exceed charging time.
- ALWAYS disconnect the charger from the scooter prior to wiping down and cleaning your scooter with liquid.

FAILURE TO HEED THE ABOVE WARNINGS INCREASES RISK OF SERIOUS INJURY. USE WITH APPROPRIATE CAUTION AND PAY CLOSE ATTENTION TO SAFE OPERATION.



## HOW TO RIDE

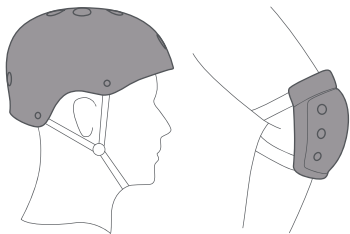

 Always wear an approved safety helmet, elbow pads and knee pads. A long-sleeve shirt and pants are recommended.

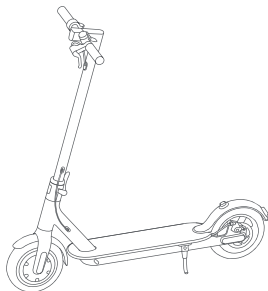

**1** Turn on the scooter, and check the power indicator.

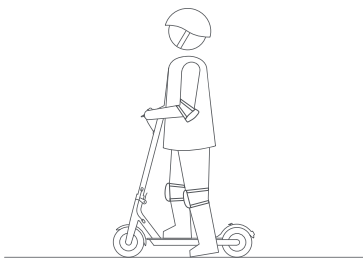

**2** Step on the deck with one foot, and slowly kick off the other on the ground.

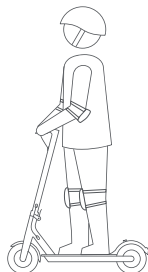
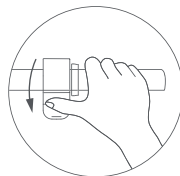

**3** When the scooter starts to coast, put both feet on the deck and press the accelerator. Note: The accelerator initiates once the coasting speed exceeds 5 km/h (3.1 m/h).

## HOW TO RIDE

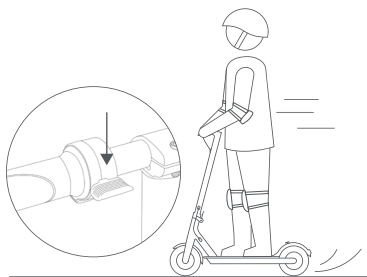

4

Release the accelerator and the kinetic energy recovery system (KERS) initiates automatically to brake slowly; press down on the brake lever to deactivate the motor and brake faster.

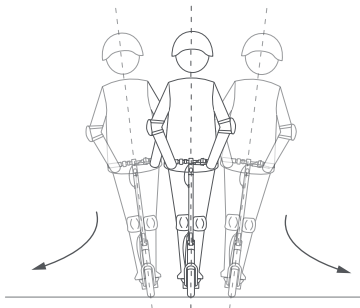

5

Tilt your body to the steering direction as you turn, and slowly turn the handlebar.

## SHOK EcoTrek Platform

The SHOK EcoTrek Platform features a Kinetic Energy Recovery System (KERS) which recovers the scooter's kinetic energy under deceleration, and uses it to recharge the scooter battery. The KERS improves the range of the scooter, and maximizes battery life, so you get the most out of every ride. It is recommended to use the KERS to slow the scooter when only gentle deceleration is required instead of manual braking. This saves wear and tear on the brake assemblies, and prolongs the life of the battery and the scooter.

At the heart of the SHOK EcoTrek Platform is a high purity copper motor with built-in cruise control, which reduces motor weight and increases motor efficiencies during operation.

An intelligent battery with built in Smart chip records battery usage, charging, and discharging for optimal battery life. It also provides protection from short circuit, overcurrent, under voltage, overcharge, and over discharge.

A robust smart controller connects it all together to improve the performance of the motor and battery, and extend the life of the electric scooter.

# SAFETY INSTRUCTIONS

## Watch out for the following safety risks



DO NOT ride the scooter in wet weather. It is dangerous and may result in injury. Wet conditions can damage the electronics and void the warranty.

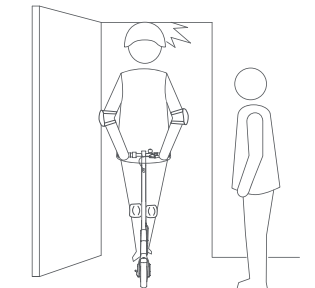

NEVER ride the scooter indoors. You may risk injury or cause damage to personal and private property.

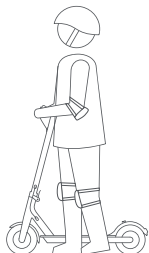
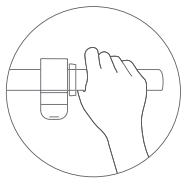

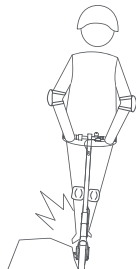

DO NOT press the accelerator unless you are on the scooter and in an environment suitable for riding.



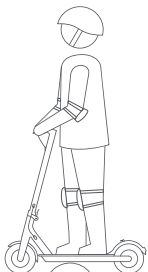

ALWAYS steer clear of potential obstacles that could catch your wheel or force you to swerve suddenly and lose control of the scooter.

## SAFETY INSTRUCTIONS

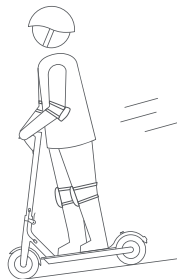

-  Keep your speed between 5–10 km/h (3.1–6.2 m/h) when riding over speed bumps, or bumpy roads. Slightly bend your knees to adapt to uneven surfaces.



-  DO NOT accelerate when going downhill, and brake in time to slow down. When encountering a steep incline, step off the scooter and push. Do not attempt to ride up.

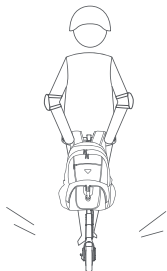

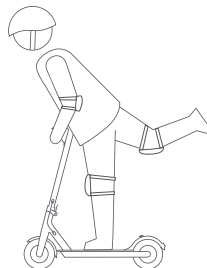

-  DO NOT hang bags or other heavy items on the handlebars.



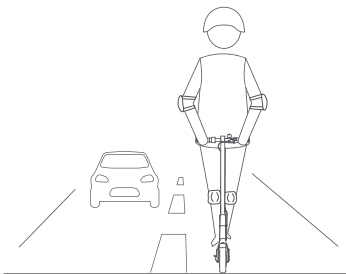

-  DO NOT ride on a single foot.

## SAFETY INSTRUCTIONS

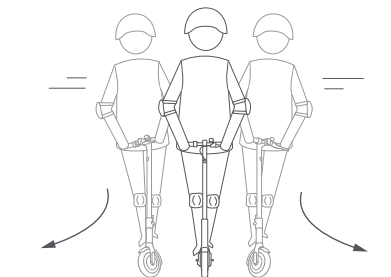

 DO NOT ride in traffic lanes or residential areas where vehicles and pedestrians are both allowed.



 DO NOT abruptly change the steering direction.



 DO NOT ride through puddles or any other (water) obstacles. Slow down and bypass them.

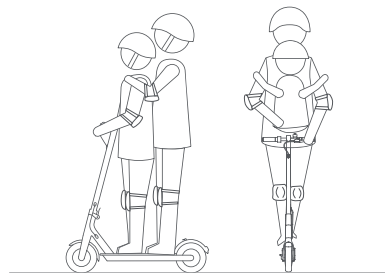

 NEVER allow more than one person at a time to ride the scooter, including children.

## SAFETY INSTRUCTIONS

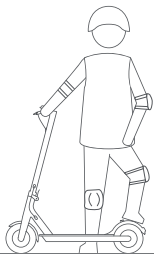

DO NOT keep your feet on the rear mudguard.

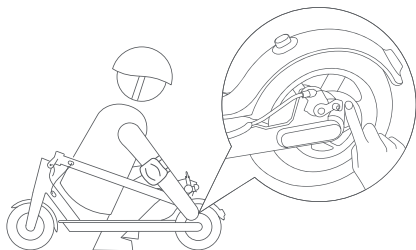

DO NOT touch the disc brakes or motor on the scooter when in use, or immediately after riding, as these parts can become very hot.



DO NOT remove your hands from the handlebars while riding.

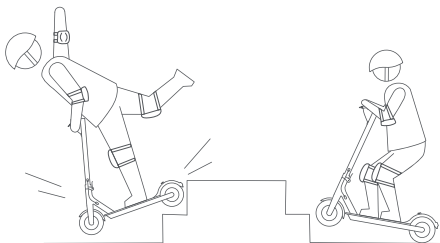

DO NOT attempt to jump over obstacles, do stunts, or tricks, on your electric scooter. The scooter is not made to withstand abuse from misuse such as jumping, curb grinding, or any other type of stunts.

## SAFETY REMINDER

**WARNING:** Riding the electric scooter can be a hazardous activity. Whenever you ride the electric scooter, you risk severe injury or even death from loss of control, collisions, and falls. **USE CAUTION AND RIDE AT YOUR OWN RISK.**

- ALWAYS check and obey any local laws or regulations which may affect where the electric scooter may be used.
- Be careful to avoid pedestrians, skaters, skateboards, scooters, bikes, children or animals who may enter your path, and respect the rights and property of others.
- ALWAYS wear proper protective equipment such as an approved safety helmet, elbow pads and kneepads. A long-sleeved shirt, long pants, and gloves are recommended. Always wear athletic shoes (lace-up shoes with rubber soles). NEVER ride barefooted or in sandals, and keep shoelaces tied and out of the way of the wheels, motor and drive system.
- Make sure your scooter has a full battery before taking it out to ride.
- DO NOT ride the scooter under the influence of drugs or alcohol.
- Be sure to check the scooter before every use, and make certain it is operating correctly. Check that the braking system is functioning properly, and any and all axle guards, chain guards, or other covers or guards supplied, are in their proper place and in serviceable condition. Ensure that the tires are in good shape, and have sufficient tread remaining. If you notice loose parts, low battery alerts, flat tires, excessive wear, strange sounds, malfunctions and other abnormal conditions, stop riding immediately and call for professional support.
- DO NOT modify the scooter from the manufacturer's original design.
- NEVER exceed the 60 kg (132 lbs) maximum load rating.
- Keep your fingers and other body parts away from the steering system, wheels and all other moving components while operating the scooter.
- NEVER use headphones or a cell phone when riding.
- NEVER hitch a ride with another vehicle.
- DO NOT ride at night or when visibility is limited.

# FOLDING & CARRYING

## Folding the Scooter

Make sure that the scooter is turned off before folding. To fold, pull the quick release lever on the folding assembly to unlock. Then bend the handlebar stem, pulling it down towards the rear wheel.

To open, pull the handlebar stem up, and close the quick release lever on the folding assembly.

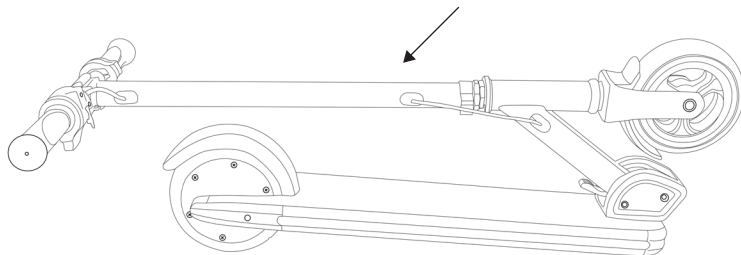
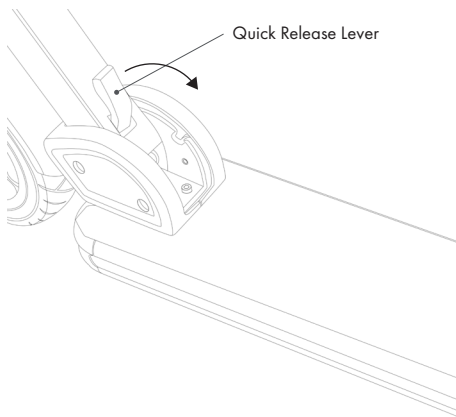



## FOLDING & CARRYING

### Carrying the Scooter

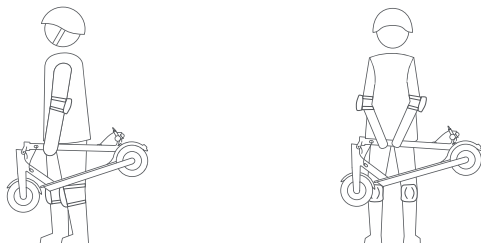

Once the scooter is folded, lift the scooter by the stem to carry, using either one hand or both hands.

## DAILY CARE & MAINTENANCE

### Adjusting the Handlebar

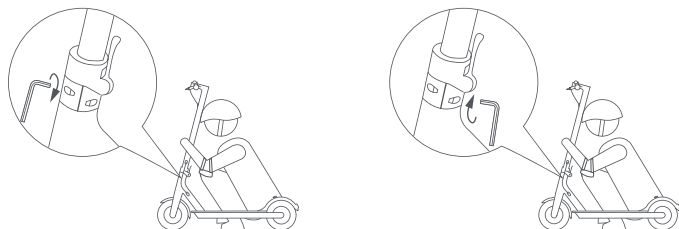

Long-term use of the scooter may result in loose screws, causing the handlebar stem to become unstable. If you notice the handlebar stem is shaky or loose when riding, use the 4 mm Allen key to tighten the screws on the holding mechanism.

# DAILY CARE & MAINTENANCE

## Cleaning

To clean the scooter, wipe it with a damp cloth. DO NOT use alcohol, gasoline, kerosene, or other corrosive chemical solvents to clean the scooter. It can severely damage the appearance and structure of the scooter. DO NOT use a pressure washer as it may cause damage to the electronics. During cleaning, make sure that the scooter is turned off, the charging cable is unplugged, and the charging port cover is closed, as water leakage may result in electric shock or damage to the electronics, voiding the warranty.

## Storage

When the scooter is not in use, keep it indoors and store it in a cool, dry place. Avoid storing the scooter outdoors. Excessive sun exposure can damage the scooter's appearance, while overheating and overcooling accelerate tire aging, and compromise the battery pack's lifespan.

## Battery Maintenance

- Use original battery packs, use of other models or brands may be dangerous.
- DO NOT touch the contacts. DO NOT dismantle or puncture the casing. Keep the contacts away from metal objects to prevent short circuits which may result in battery damage or even injuries and deaths.
- Only use the approved power adapter to avoid potential damage to the battery or fire.
- Improper disposal of used batteries may do serious harm to the environment. Make sure to follow local regulations to properly dispose of used batteries.
- After every use, fully charge the battery to prolong its lifespan. DO NOT ride until the battery is fully out of power.
- DO NOT place the battery in an environment where the ambient temperature is higher than 50 °C (122 °F) or lower than -20 °C (-4 °F).

NOTE: a fully charged scooter will last for 120–180 days. The built-in intelligent chip will keep a log of its charging and discharging records. The damage caused by prolonged no charge is irreversible and is beyond limited warranty.

# SPECIFICATIONS

Performance Index	Items	Electron
Dimensions	Before Folding	L: 85 cm (33.5 in) x W: 40 cm (15.8 in) x H: 85 cm (33.5 in) <sup>[1]</sup>
	After Folding	L: 85 cm (33.5 in) x W: 40 cm (15.8 in) x H: 28 cm (11 in) <sup>[1]</sup>
Weight	Item weight	5.7 kg (12.6 lbs)
Riding Requirements	Max load	60 kg (132 lbs)
	Age	6–12
	Rider height	1.4 m (55 in)
Main Parameters	Max. speed	16 km/h (10 m/h)
	Max. climbing angle	Approx. 7 °
	General range	Approx. 7 km (4.4 mi) <sup>[2]</sup>
	Traversable terrain	Cement and asphalt roads; obstacles < 1 cm (0.4 in); gaps < 3 cm (1.2 in)
	Operating temperature	0–35 °C [32–95 °F]
	IP rating/Water resistance	IP45
Battery Pack	Voltage	24 V lithium ion battery
	Nominal battery capacity	48 Wh
	Battery size	2.0 Ah
	Intelligent battery	Short circuit/under voltage/overcurrent/overcharge/over-discharge protections
Wheel Motor	Rate power	150 W
	Max. power	300 W
Wheel	Tires	6 in (145x40) solid tire
Charging Adapter	Output voltage	25.2 V
	Output current	0.5 A
	Charging time	Around 2–3 hrs

[1] Item height: from the ground to the top of the scooter;

[2] General range: measured when there is no wind, at a temperature of 25 °C (77 °F), with the scooter fully charged, and driven at a even speed of 15 km/h (9.3 m/h) on a flat surface, with a load of 75 kg (165.3 lbs).

NOTE: data and specifications may vary due to different models, and are subject to change without notice.

## PARTS & ACCESSORIES

Take your ride to the next level with SHOK exclusive safety gear and special attachments. Sold separately.



**Helmets**



**Phone Holders**



**Bags**



**Locks**



**Padding**



**Seats**

# ERROR CODES

## Electron Error Codes

In the rare occurrence of scooter malfunction, an error code may be displayed on the scooter control panel. The table below lists potential error codes, their descriptions, and possible solutions when troubleshooting.

Error Code	Description	Solution
E0	Brake Error	Check the brake handle and brake line, if damaged replace it.
E1	Communication Error	Check the controller connection, if damaged replace it.
E2	Hall Line Error	Motor Hall line is loose, out of order, or internal Hall sensor is damaged. Check the connection cables, if damaged replace it.
E3	High Temp Protect	Scooter temperature is too high. Turn off the scooter and let it rest to cool down. If the problem persists, check the controller, and replace it if necessary.
E4	Controller Error	Check the controller connection, if damaged replace it.
E5	Battery Low Voltage	Battery undervoltage, charge it first, if still non-operational, replace the battery.
E6	Motor Stuck	Check the controller, if damaged replace it.
E7	Accelerator Failed	Speed out of control. Check the accelerator, if damaged replace it. If accelerator is working normally, check the controller.
E8	Over Current Protect	Electric current exceeded. Turn the scooter off, and turn on several minutes later. If still non-operational, replace the mainboard.
E9	Over Voltage Protect	High voltage from the battery to the controller. Turn the scooter off, and turn on several minutes later. If still non-operational, check the battery and controller, and replace if necessary.

# WARRANTY

## 90 Day Limited Warranty

The manufacturer warrants this product to be free of manufacturing defects for a period of 90 days from date of purchase. This 90 Day Limited Warranty covers the battery, electric motor, and controller. This 90 Day Limited Warranty does not cover normal wear and tear, tires, tubes or cables, or any damage, failure or loss caused by improper assembly, maintenance, storage or use of the scooter.

### To Qualify for Warranty Service:

- You must present a copy of the sales receipt within 90 days of purchase.
- The product cannot be modified in any way.
- The product cannot be used for rental or commercial use, or in competition.

### Limitations of Liability

- This Limited 90 Day Warranty is non-transferable after the product's initial sale.
- Units replaced under warranty are not covered by any additional warranty.
- Warranty is void if the scooter shows visible signs of damage or has been misused beyond what is considered normal use, including water damage.
- Damage due to misuse or neglect, or use other than as specified in the User's Manual, are not covered by this Limited 90 Day Warranty.
- Warranty is void if weather related water damage is determined. The owner is responsible for storage and protection of the scooter from the weather.
- This Limited 90 Day Warranty does not cover minor surface blemishes, rips, tears, or other cosmetic damage due to normal use, nor does it cover any damage which results from aging, such as fading of paint, deterioration of plated surfaces, deterioration of rubber or plastics, or rusting.
- This Limited 90 Day Warranty will not cover any damage which results from the application of improper cleaners, solvents or chemicals to the product, water damage, smoke or soot, or from exposure to saltwater, sea breeze or salt.